

HƯỚNG DẪN SỬ DỤNG SERVO DRIVER DA98A SERIES

1. SƠ ĐỒ ĐẦU NỐI:

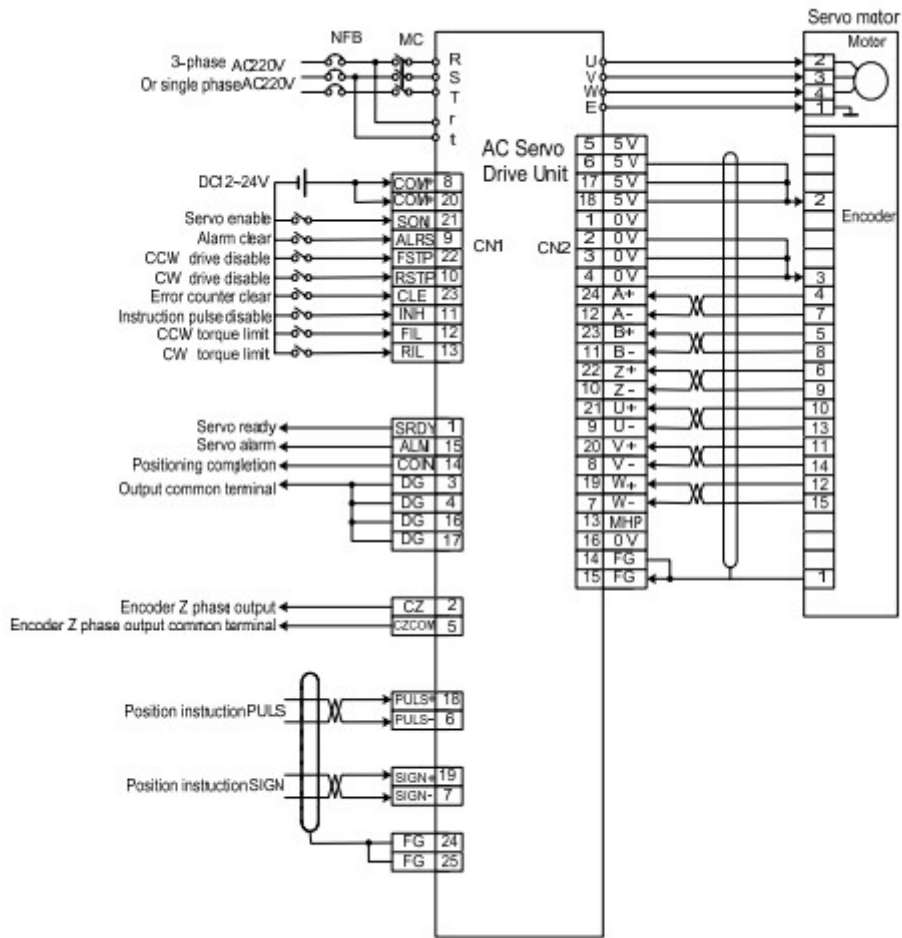

TB



CN1

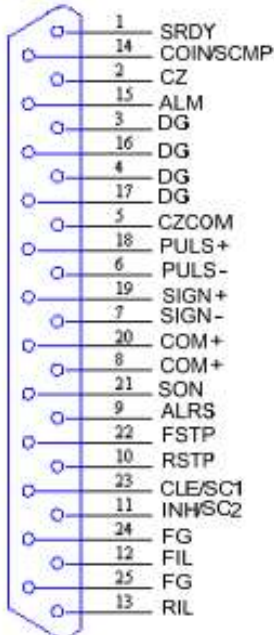

DB25

CN2

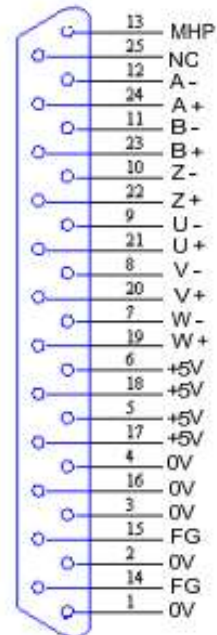

DB25

2. Các thông số quan trọng:

- Pn.04: Lựa chọn chế độ điều khiển:

0 – Position control mode.

1 – Speed control mode.

2 – Trial control mode.

3 – Jog mode.

- Pn.14: Lựa chọn kiểu phát xung:

0 – Pulse/Direction.

1 – CWW/CW.

3. Bảng mã lỗi:

Alarm code	Alarm name	Content
--	Normal	
1	Overspeed	The servo motor speed exceeds its setting value.
2	Main circuit overvoltage	Power voltage of main circuit is too high.
3	Main circuit undervoltage.	Power voltage of main circuit is too low.
4	Position out-of-tolerance	The value of position deviator exceeds its setting value.
5	Motor overheated	Motor temperature is too high.
6	Saturation fault of speed amplifier	Speed amplifier saturation is too long.
7	Drive stop abnormal	Both CCW, CW drive stop inputs are OFF.
8	The position deviator overflow	Absolute value of position deviator exceeds 2^{30} .
9	Encoder fault	Encoder signal has errors.
10	Control power supply undervoltage	Control power supply is $\pm 15V$ lower.
11	IPM module fault	IPM intelligent module is at fault.
12	Overcurrent	Motor current is too large.
13	Overload	The AC servo drive unit and motor are overloaded (instantaneous overheating).
14	Brake fault	Brake circuit is at fault.

15	Encoder counting error	Encoder counting is abnormal.
16	Motor heat overloading	The electrothermal value of the motor exceeds the setting value (I^2t detection).
19	Thermal reset	The system is thermally reset.
20	IC4(EEPROM) error	IC4 (EEPROM) is at fault.
21	IC3(PWM chip) error	IC3 (PWM chip) is at fault.
22	IC2(CODER chip) error	IC2 (CODER chip) is at fault.
23	IC7(A/D chip) error	IC7 (A/D chip) or current sensor is at fault.
30	Encoder Z pulse lost	Encoder Z pulse is at fault.
31	Encoder UVW signal error	Encoder U, V, W signal is at fault or not suited with encoder.
32	Encoder UVW signal illegal encoding	U,V,W signals are all high level or all low level.